

Rope Driven Trolley

CG10RT, CG40RT

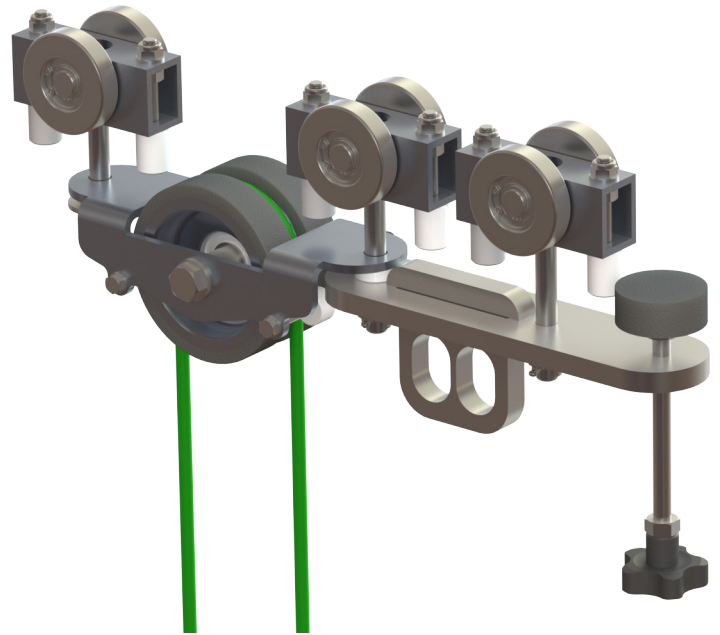
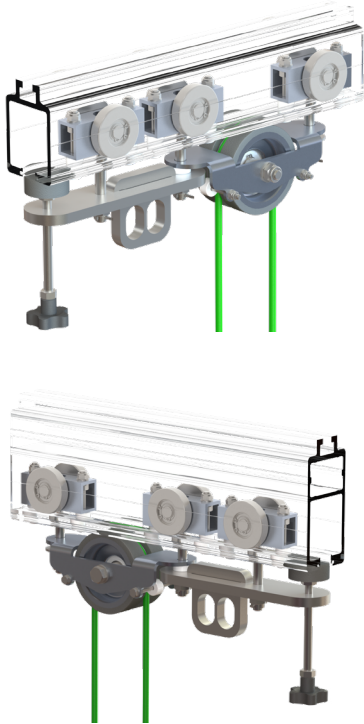

Design Standard	US OSHA1910.66 and ASME 120.1 standards
Track Type	CG10, CG40
Weight	14,13 lbs
Material	Aluminium 6060-T66 Stainless steel AISI 304
Traction Pulley Material	Aluminium with vulcanized rubber
Traction Pulley Diameter	Ø 4,13"
Bearings	Deep groove ball W
Roller Diameter	Ø 2,36"
Suspension Holes Plate Length	3,00"
Suspension Holes Upper/Lower Diameter	Ø 1,06"
Trolley Length	18,58"
Trolley Width	2,95"

The CoxGomyl™ CG10RT and CG40RT rope driven trollies work in combination with the CG10 & CG40 tracks and can be used for indoor and outdoor applications.

The trolley is moved by pulling the rope from the suspended self-powered platform. The trolley is equipped with two suspension holes, one for the suspension wire and one for the safety wire. The trolley is for use with straight and curved horizontal tracks only.

Key Features

- Suitable for indoor and outdoor use
- Constructed from corrosion resistant materials
- Premium bearings for smooth operation
- Optional manual screw brake

COXGOMYL and related logos are registered trademarks of Alimak Group AB (publ) and its subsidiaries ("Alimak Group"), in several jurisdictions, including but not limited to the EU and the United States. Alimak Group retains all rights in its name and for above mentioned trademarks, whether registered or not.