

Monorail Tracks

CG40

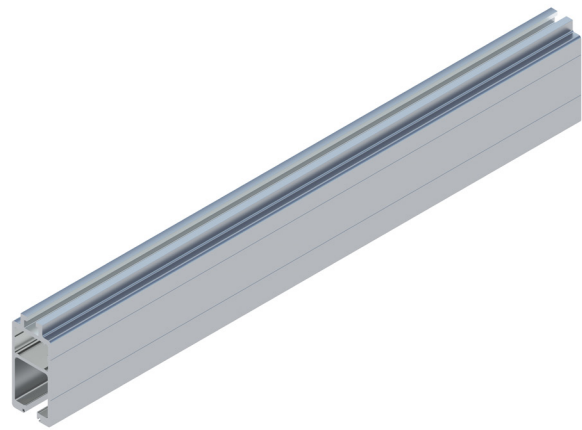
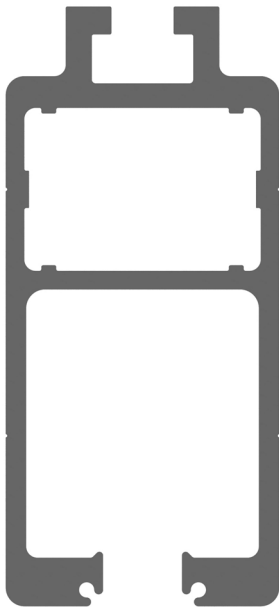

Design Standard	EN 1808
Track Type	CG40
Dimensions	160 mm x 75 mm
Weight	8.79 kg/m
Yield Limit	160 N/mm ² 240 N/mm ²
Minimum Horizontal Bend Radius	650 mm
Typical Bracket Span	2.0 m - 4.0 m
Bracket Fastening	Top
Fastening Method	2 x M16 bolts for each bracket
Material	Aluminium alloy 6063-T6 Aluminium alloy 6061-T6
Finish	Mill finish
Optional Surface Treatment	Anodized
Optional Colors	RAL 7004 RAL 9001

The CoxGomyl™ monorail is the ideal facade maintenance system for buildings with limited roof space. It can be installed with minimal visual impact respecting the architectural aesthetic. It consists of aluminium tracks in combination with the CoxGomyl trolley range and suspended platforms or as an abseil solution.

CoxGomyl CG40 monorail tracks is the preferred option when we are looking for a complete integration in the building design and looking for a solution with a higher distance between brackets or able to work under high loads. It can be installed hanging or embedded in the roof ceiling. Suitable for indoor and outdoor installations.

CoxGomyl trolleys must be used with the CG40 track.