

# Monorail Tracks

## CG40

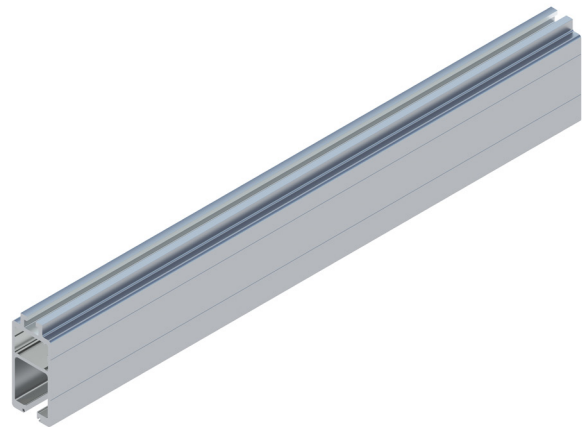
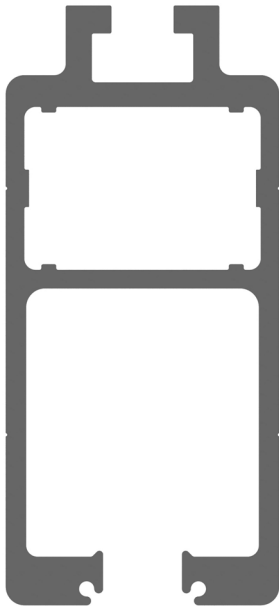

<b>Design Standard</b>	EN 1808
<b>Track Type</b>	CG40
<b>Dimensions</b>	160 mm x 75 mm
<b>Weight</b>	8.79 kg/m
<b>Yield Limit</b>	160 N/mm <sup>2</sup> 240 N/mm <sup>2</sup>
<b>Minimum Horizontal Bend Radius</b>	650 mm
<b>Typical Bracket Span</b>	2.0 m - 4.0 m
<b>Bracket Fastening</b>	Top
<b>Fastening Method</b>	2 x M16 bolts for each bracket
<b>Material</b>	Aluminium alloy 6063-T6 Aluminium alloy 6061-T6
<b>Finish</b>	Mill finish
<b>Optional Surface Treatment</b>	Anodized
<b>Optional Colors</b>	RAL 7004 RAL 9001

CoxGomyl's monorail is the ideal facade maintenance system for buildings with limited roof space. It can be installed with minimal visual impact respecting the architectural aesthetic. It consists of aluminium tracks in combination with the CoxGomyl trolley range and suspended platforms or as an abseil solution.

CoxGomyl CG40 monorail tracks is the preferred option when we are looking for a complete integration in the building design and looking for a solution with a higher distance between brackets or able to work under high loads. It can be installed hanging or embedded in the roof ceiling. Suitable for indoor and outdoor installations.

*CoxGomyl trolleys must be used with the CG40 track.*