

E3000

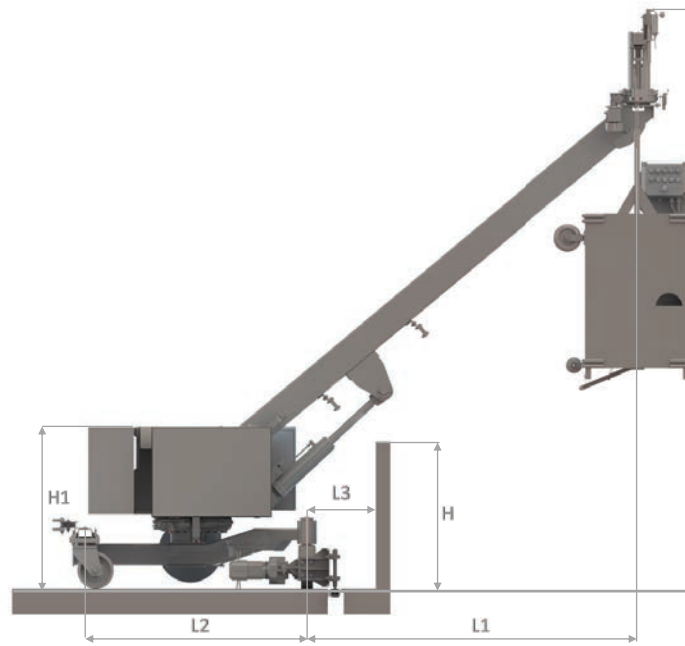

The E3000 Building Maintenance Unit (BMU) is a reliable and great value solution for buildings of lower height and uniform shape. A compact, robust and lightweight machine, the E3000 is almost entirely hidden from sight from ground level when not in use. Due to its compact profile, the E3000 machine is particularly well suited to applications with limited space on the roof and buildings with roof gardens.

The system comes with the option of jib luffing with a minimum height of 1.1 metres, allowing for discreet parking. Simple to install and operate, the E3000 delivers a reliable, low maintenance and economical access solution with a range of safety features such as upper and lower safety bars on the platform and a auxiliary hoist for replacement of facade elements such as windows.

Design Standard	EN 1808:2015
Maximum Rated Load	300 kg
Maximum Operating Height	135 m
Dimensions	L1 (max) 6000 mm L2 1200-1500-1700-2000 mm L3 (min) 350 mm H (max) 2000 mm H1 (min) 1100 mm
Wire Rope	7-8 mm Galvanised wire ropes
Crossbar Slew	± 90 °
Body Slew	± 180 °
Cradle Type	2 m Aluminium Cradle
Track System	Front Angle Guide or Twin Track

Standard Features

- Full galvanised finish
- Rollers or telescopic wheels on platform
- BMU weight < 6 Tons
- Install crane capacity required < 2 Tons
- Standard Safety Features: Hoist over speed device, cradle lower trip bar, ratcheting straps to secure the cradle, lower roller buffers, rubber protection on all corners, lower trip bar.

Optional Features

- Range of colours available
- Cable reeler (22 m)
- Auxiliary hoist - 400 kg max
- Subframe platforms
- Painted counterweight
- Track switch
- Anemometer
- Facade restraint system
- Upper trip bar
- Luffing for parking
- Cradle Complements: Upper, rear and lateral buffers, upper and lower safety bars, upper telescopic wheels, cable bag, guard rail, telephone, castor wheels, cradle paint, detachable cradle.