



3000 SERIES

BUILDING MAINTENANCE UNITS

SPECIALIST BUILDING
ACCESS SOLUTIONS



The 3000 Series is designed to provide reliable, economical facade access solutions for buildings of uniform shape, with prompt delivery times of 12 weeks or less.

Introducing the CoxGomyl 3000 Series

The CoxGomyl 3000 Series of machines is designed to provide reliable, economical facade access solutions for buildings of uniform shape, with prompt delivery times of 12 weeks or less for any machine in the range.

As industry leaders and one of the only true end-to-end building access providers in the world, CoxGomyl have brought all of our experience and expertise in design, engineering and manufacturing in to developing this range of practical and cost-effective facade access solutions. By utilising standard components and configurations that will satisfy the access requirements for many buildings of uniform shape we are able to offer a high level of functionality and quality, combined with value and prompt delivery. Due to the lightweight

construction, the building maintenance units in this range are often suitable for replacing older, outdated access systems.

A set range of selection criteria has been defined to help in the identification of the most suitable product type at a high level. Operational options are also listed to assist in indicating the range of possibilities within the 3000 Series. It is recommended that you consult with a CoxGomyl design expert who can work with you on identifying the optimal cost-effective solution for your requirements.

The 3000 Series currently consists of 2 products, the E3000 and the F3000.



E3000

The E3000 Building Maintenance Unit (BMU) is a reliable and great value solution for buildings of lower height and uniform shape. A compact, robust and lightweight machine, the E3000 is almost entirely hidden from sight from ground level when not in use. Due to its compact profile, the E3000 machine is particularly well suited to applications with limited space on the roof and buildings with roof gardens. The system comes with the option of jib luffing with a minimum height of 1.1 metres, allowing for discreet parking. Simple to install and operate, the E3000 delivers a reliable, low maintenance and economical access solution with a range of safety features such as upper and lower safety bars on the platform and a auxiliary hoist for replacement of facade elements such as windows.

Standard Features:

- 2m aluminium cradle
- Full galvanised finish
- Rollers or telescopic wheels on platform
- Full range of safety features (see specification sheet)
- BMU weight < 6 Tons
- Install crane capacity required < 2 Tons
- Delivery in 12 weeks or less

Optional Features:

- Range of colours available
- 22m cable reeler
- Luffing for parking
- Auxiliary hoist - 400kg max
- Painted counterweight
- Subframe platforms
- Track switch
- Detachable cradle
- Range of cradle components

Selected if:

- Required outreach is up to 6m
- Building height is up to 135m
- Hidden parking is required
- min. parking height is 1.1m
- The visual impact of the machine needs to be minimised. e.g. for Green Roof Buildings



Request the E3000 Specification Sheet for more information

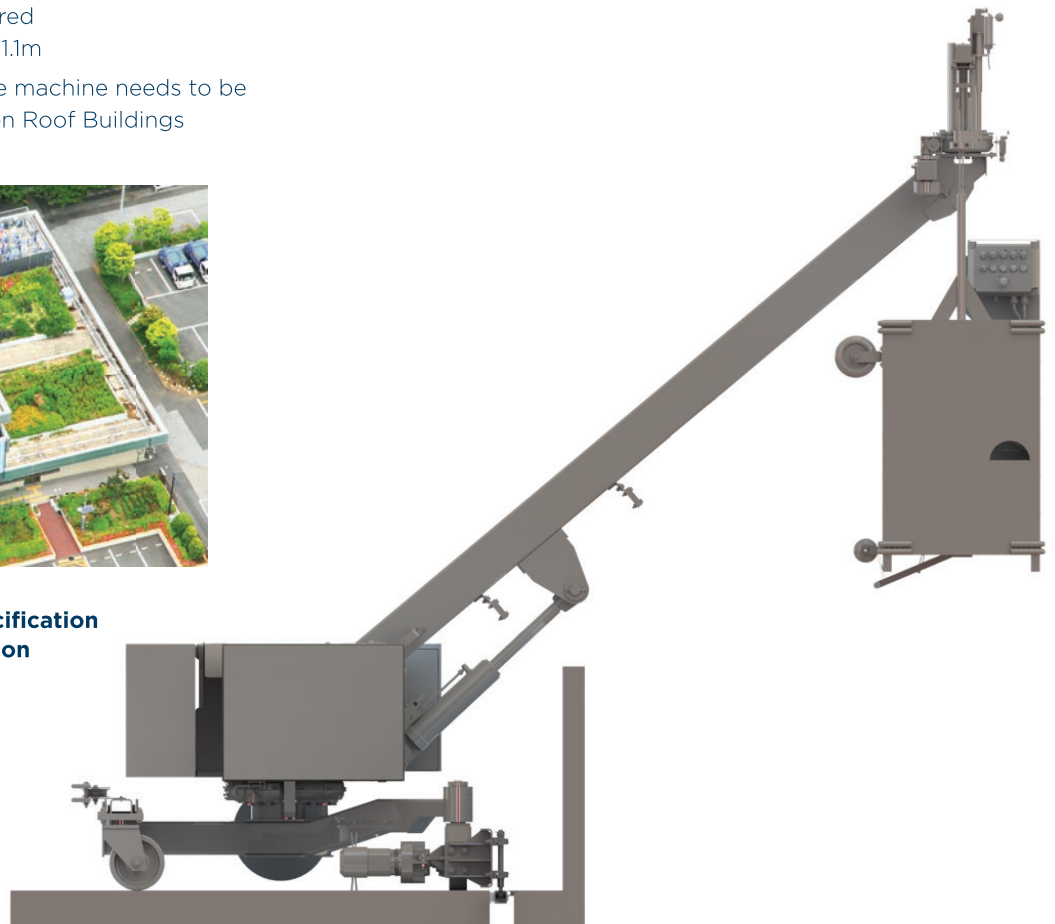



F3000

Often referred to as a 'crane type' Building Maintenance Unit (BMU), the F3000 is used when the reach or suspended load is increased beyond the capabilities of the E-type machines. This economical BMU has an impressive higher load capacity of 500kg for the auxiliary hoist and a reach of up to 14 metres, all of which can be delivered in no more than 12 weeks. Like the E3000 machines the F3000 features upper and lower safety bars on the platform and a glass hoist for window replacement. The F3000 is simple to install, safe to operate and adjustable in reach, drop and gauge. The F3000 is also suitable for replacements due to its lightweight, robust construction.

Standard Features:

- 2m aluminium cradle
- Full galvanised finish
- Rollers or telescopic wheels on platform
- Full range of safety features (see specification sheet)
- BMU Weight max < 10 Tons
- Install crane capacity required < 2 Tons
- Delivery in 12 weeks or less

Selected if:

- Required outreach is up to 14m from slew
- Building height is up to 240m
- Building shape and roof plan are simple
- Sub-assemblies with a weight less than 2 tons

Optional Features:

- Range of colours available
- Cable reeler (22m)
- Auxiliary hoist - 500kg max
- Painted counterweight
- Subframe platforms
- Track switch
- Anemometer
- Detachable cradle
- Range of cradle components

Request the F3000 Specification Sheet for more information

Options available for the 3000 Series BMU's

Depending on your requirements CoxGomyl's standard 3000 Series range of products can be modified with a range of additional cradle and system components such as:

- Telescopic wheels
- Soft rollers
- Upper trip bars
- Castor wheels
- Telephone
- Range of frame colours

The Cradle

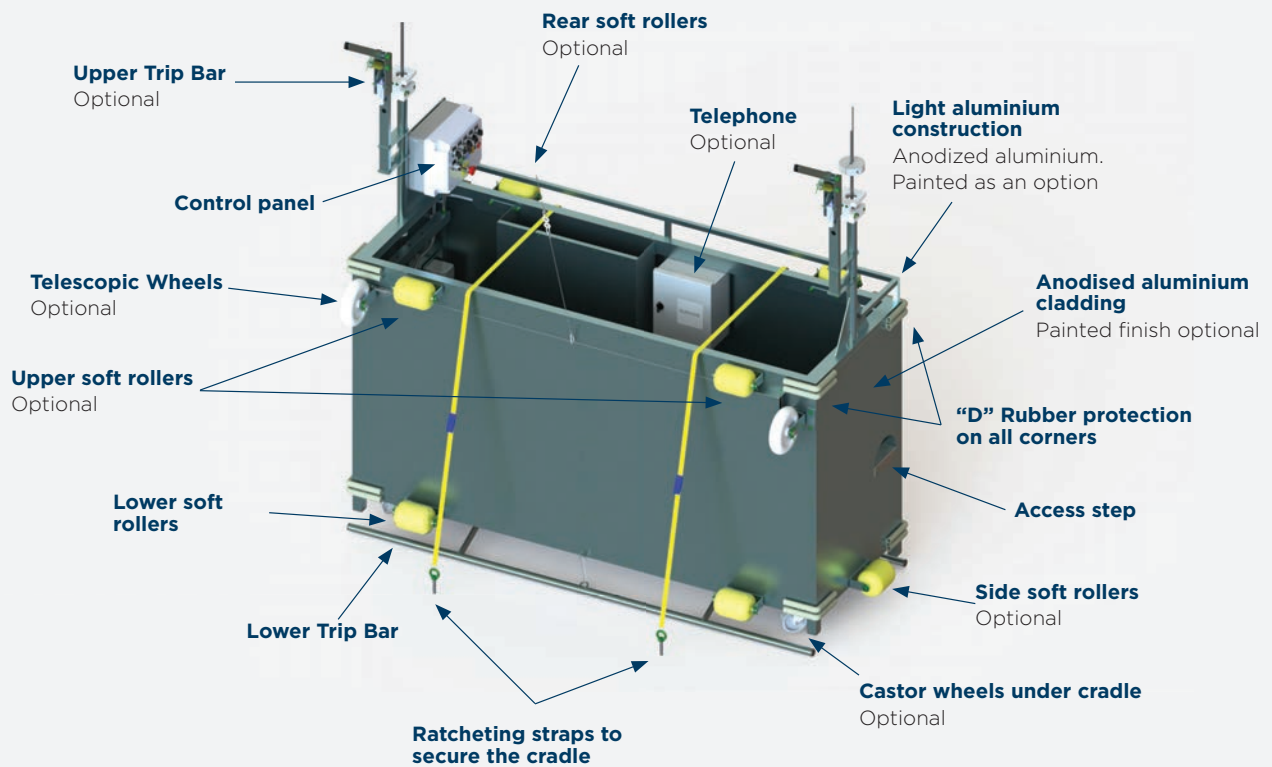

F3000

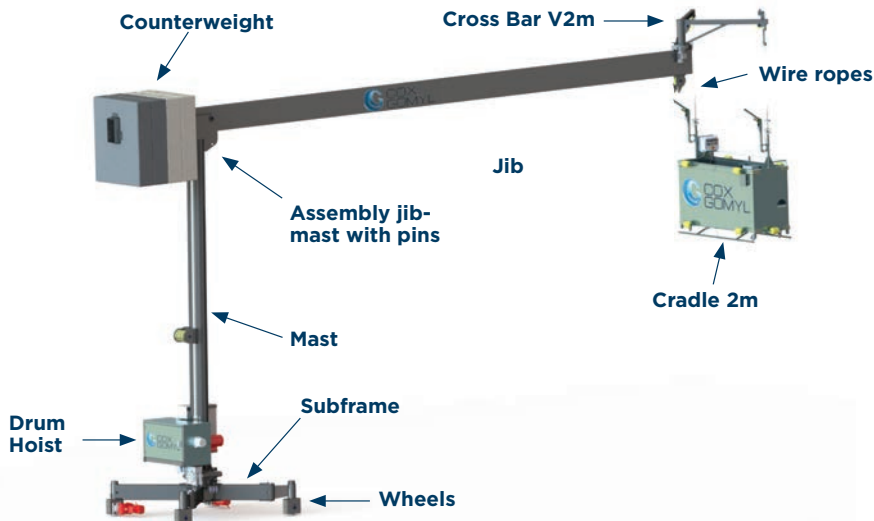

E3000

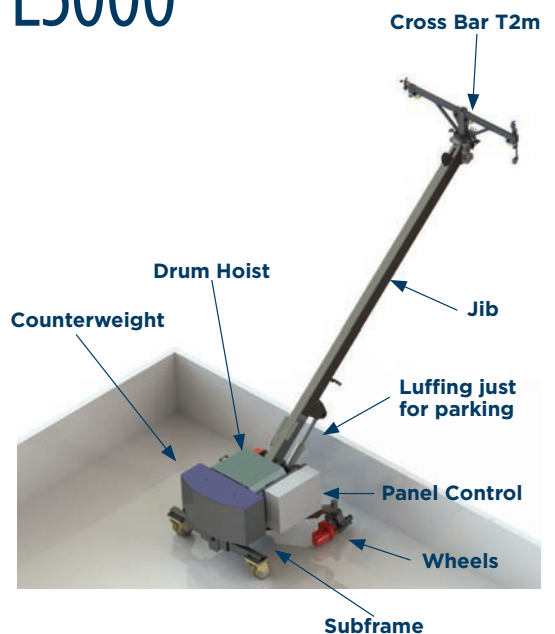

Our Services

We take responsibility for producing outstanding building and facade access solutions, and as such, are the largest full solution provider in the industry. CoxGomyl have experts in engineering, design, project management, implementation, safety and maintenance, to bring a complete 'end to end' spectrum of capabilities to your corner of the globe. This means we are ideally positioned to provide the economical solutions of the 3000 Series range and satisfy demands for fast delivery times.

Our expert team will work with you on final drawings and engineering calculations to ensure that all areas of the facade surface are reached, loads are understood and our project managers are integrating with your teams. From there the system will go into production and is seamlessly delivered and installed on the location.

CoxGomyl has been involved in thousands of building solutions over the past six decades in over 50 countries around the world. Our local and regional network of sales offices, project managers, and installation teams will work with you to deliver an installation that is smoothly executed, on time and on budget. After installing, we remain available to assist with the servicing and maintenance during the DLP period, as well as offering ongoing full maintenance and service packages.

There is a peace of mind that comes from having your long-life capital equipment maintained fully by the manufacturer. It ensures up time, a clean and well-maintained building, lower cost of ownership, and ultimately assists in the delivery of your value proposition with clients and tenants.

As a global leader our products can be designed to meet your local industry standards such as EN1808:2015 (European), GB19154.2003 (Chinese), SS CP 20/1999 (Singapore) or PB.10.518.02 (Russian).

If you would like to discuss the 3000 Series further, please contact your regional office (see overleaf for details). Remember to refer to the 1000 Series, 5000 Series and 7000 Series brochures if you feel you require an even simpler or more complex system than outlined within the capabilities of the 3000 Series range. With such a vast product range and every buildings being different, we recommend you consult directly with a CoxGomyl Sales Advisor, who can assist in developing the optimal solution and the smooth end-to-end planning and execution of your project on time.

Both the E3000 and F3000 are available with a range of wheel options to suit your project requirements.

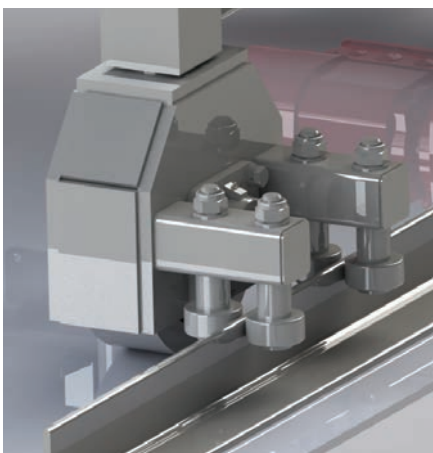

L Front Guided Wheel

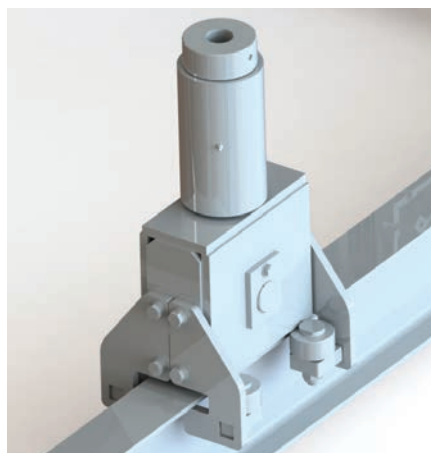

Twin Track

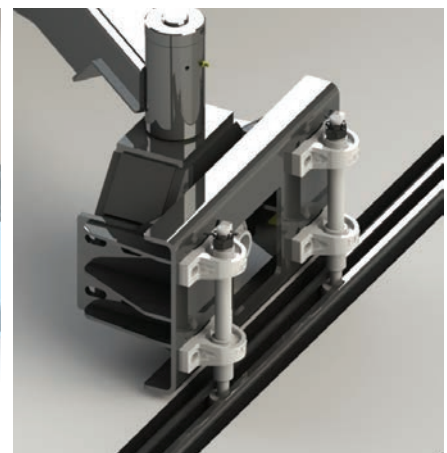

U Front Guided Wheel

See our Design, Project Management and Installation brochure for further information or visit www.coxgomyl.com

CoxGomyl Office locations:

Asia Pacific Region

Australian Office
182 Normanby Road
Southbank, Vic 3006, Australia
Phone: +61 3 9673 4444
Fax: +61 3 9673 4400
Email: headoffice@coxgomyl.com

Hong Kong and South China Office
Flat 04A, 11th Floor, Eastern Centre
1065 King's Road, Quarry Bay
Hong Kong SAR
Phone: +852 2802 2221
Fax: +852 2824 9626
Email: hongkong@coxgomyl.com

Central and North China Office
Rm.606 Tong Sheng Tower
No. 458 FuShan Road
Shanghai, China 200122
Phone: +86 21 5465 2455
Fax: +86 21 6467 7507
Email: shanghai@coxgomyl.com

South East Asia Office
18 Boon Lay Way, Tradehub 21
#03-125
Singapore 609966
Phone: +65 6513 4780
Fax: +65 6425 6100
Email: singapore@coxgomyl.com

Europe Region

Western Europe and Latin America Office
Calle de la Venta, no 19
28880 Meco, Madrid
Spain
Phone: +34 9188 77000
Fax: +34 9188 60514
Email: madrid@coxgomyl.com

United Kingdom Office
19 Schooner Park, Schooner Court,
Crossways Business Park, Dartford,
DA2 6NW, United Kingdom
Phone: +44 1322 221414
Fax: +44 1322 228419
Email: london@coxgomyl.com

Russia and East Europe Office
3Pl. Tverskaya Zastava, Office 240
Moscow, Russia, 125047
Phone: +7 499 250 8975
Fax: +7 499 250 2729
Email: russia@coxgomyl.com

Rest of the World (ROW) Region

Australia and NZ Office
182 Normanby Road
Southbank, Vic 3006, Australia
Phone: +61 3 9673 4444
Fax: +61 3 9673 4400
Email: melbourne@coxgomyl.com

Middle East Regional Office
PO Box 33654
Dubai, UAE
Phone: +971 4 511 8200
Fax: +971 4 511 8300
Email: dubai@coxgomyl.com

Abu Dhabi Commercial Mussafah
ME 12, Building 232, Office M1
Abu Dhabi, UAE
Phone: +971 4 511 8200
Fax: +971 4 511 8300

North America Office
216 North Avenue East
Cranford, NJ 07016, USA
Phone: +1 908 325 6587
Fax: +1 908 967 6042
Email: usa@coxgomyl.com

coxgomyl.com

