



5000 SERIES

BUILDING MAINTENANCE UNITS

SPECIALIST BUILDING
ACCESS SOLUTIONS



This page: Gateway, Sydney
Cover: Bligh St, Sydney

Introducing the CoxGomyl 5000 Range

The CoxGomyl 5000 Series machines are designed for use on buildings of moderate complexity, and offer capabilities beyond that of the standard configurations within the 1000 Series. When developing concepts using the 5000 Series range, the designers at CoxGomyl draw from a collection of standard features and options, to achieve a solution perfectly tailored to the architectural and functional requirements of the building. For the few and even more unique access requirements that can't be solved by the 5000 range, the CoxGomyl technical representatives will be able to put together an integrated customised solution utilising specialised engineering capabilities and componentry from the 7000 Series.

The 5000 series of products are divided into three main groups;

- E range:** Economical choice for low height/complexity
- F range:** Flexible and covers most applications
- G range:** Grand. Very large machines for specialist needs

The selection keys beside each product are designed to help in the identification of the most suitable product type at a high level, based on machine outreach as criteria. Operational options and movements are also listed to assist in indicating the huge range of possibilities within the 5000 series. It is recommended that you consult with a CoxGomyl design expert who can work with you on identifying the optimal solution for your unique requirements.



Medini Dinc, Turkmenistan

When developing concepts using the 5000 Series range, the designers at CoxGomyl draw from a collection of standard features and options, to achieve a solution perfectly tailored to the architectural and functional requirements of the building.

E-TYPE: The Economical Short Reach Choice

The E Type machines are made from standardised components and are designed to be an economical choice, with reach of up to 8 metres. With a well thought out design, E-type machines are low maintenance and safe to operate. There are three main derivatives in the range:

E1 - Machine Features

- Twin fixed-length jibs, always with jib luffing. This feature is needed to launch the cradle out over the side of the building, and to return it to the roof to allow the operators to exit.
- Generally use standard cradles.
- Can be offered with a full range of track types.

Selected if:

- The shape of the building or the lifting / cradle requirements are not complex
- Looking for the most economical solution
- Required outreach from the front wheels is 0-5m
- Building height is up to 60m.



Beale St, San Francisco



Hysan Place, Hong Kong



Zen, Melbourne

E2 - Machine Features

- Single or twin fixed-length jib machine.
- Includes machine slewing as standard, to allow the cradle to be launched and landed.
- Incorporates some form of cradle slewing as standard.
- Can be provided with a full range of cradles.
- Can be offered with a full range of track types.

Selected in preference to an E1 when:

- Building features prevent the machine from launching the cradle directly out in front
- If reduced clear width is available
- Required outreach from the front wheels is 0-5m
- Building height is up to 120m.

E3 - Machine Features

- Single fixed length jib machine.
- Shares most of the features with E2, but can generally achieve the same reach for lower overall machine mass.
- Generally requires less space to operate in.
- Can be provided with a full range of cradles.
- Can be offered with a full range of track types.

Selected if:

- Machine mass is a critical issue
- Less clear roof space is available
- Required outreach from the front wheels is 0-8m.
- Building height is up to 450m.

F-TYPE: The Flexible Choice

Often referred to as 'crane type' BMU, the F-type is used when the reach or suspended load is increased beyond the capabilities of the E-type. Due to their larger mass, F-type machines will generally operate on twin steel rails.

Torre Iberdrola, Bilbao

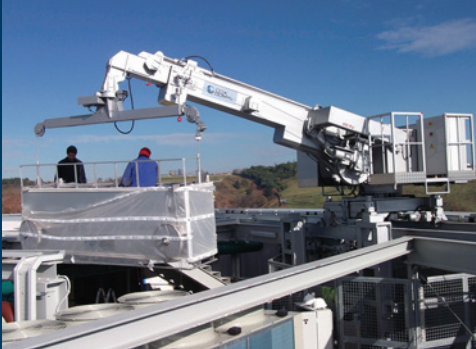

Medini Dinc, Turkmenistan



World Tower, Sydney



F1 - Machine Features

- The frame housing the hoist is part of the main structural frame of the machine.
- Can be provided with telescoping jib and a full range of cradles.

Selected if:

- There is minimal space at the back for the counterweight
- Required outreach generally in the 5-15m range
- Building height is up to 450m.

Eco Berrini, Sao Paulo



IEC Tower, Haifa



Aicon Tower, Mexico City



F2 - Machine Features

- Mast and Jib design.
- Required outreach generally in the 6-25m range.
- Can be provided with high masts to reach up and over plan rooms or other roof features.
- Can be provided with telescoping / luffing jib and a full range of cradles.
- Can be provided with a fixed, telescopic or pantograph mast.
- Can be provided as a fixed or travelling machine.

Selected if:

- Reach is above 6m with high parapets
- Reach is generally in the 15-25m range
- A lighter solution than the F1 is needed
- Need to climb sloping roofs
- Building height is up to 450m.



One Raffles Place, Singapore

G-TYPE: The Grand Choice



The Walbrook, London

Sharing many of the features of the F-type, the G-type was designed for larger buildings or where a larger reach is required. Typically, G-type machines have a reach of 25 to 50 metres, a wide range of cradles and approaching systems, as well as different climbing options for moving the BMU on pitched surfaces.

G2 - Machine Features

- Mast and Jib design, a larger version of the F2.
- Required outreach generally in the 25-50m range.
- Can be provided with high masts to reach up and over plan rooms or other roof features.
- Can be provided with telescoping / luffing jib and a full range of cradles.
- Can be provided with a fixed, telescopic or pantograph mast.
- Can be provided as a fixed or travelling machine.

Selected if:

- Reach is 25-50m
- Size is not a constraint
- Need to climb sloping roofs
- Building height is up to 500m.

Options Available for 5000 Series BMU's

Depending on your building needs, CoxGomyl BMUs can be modified with different mounting options, parking systems, machine movements, cradles, and façade restraints:

Mounting Options

- Trackless
- Concrete runway and guided angle
- Free standing twin track
- Twin track, cast in bolts
- Vertical parapet mount

Parking Systems

- Pantograph systems (mast lowering)
- Garages
- Pits and lifting tables
- Telescoping (mast lowering)

Cradles

The cradle (also known as the platform, scaffold, cage, or gondola) is the 'basket' in which the operators

stand to access the façade. Cradle design can vary to match the requirements of the façade. Cradles can be provided in lengths as short as 1.5 metres and as long as 15 metres. They can be wider to provide improved access to small recessed areas in the façade, or can incorporate a range of extendable structures (forward reaching or approaching systems) to allow them to reach into larger recessed areas (up to 6 metres). In order to prevent damage to the façade, a wide range of fixed and adjustable rollers and buffers are available. CoxGomyl cradles can also be specified with a wide range of optional extras.

Façade Restraint Options

- ISA pins with lanyards
- Soft rope system
- Pull in system
- Mullion guides.

These optional features are available for most machines but not all. For further information you can discuss your needs and application with your CoxGomyl client representative.

Machine Movement Options

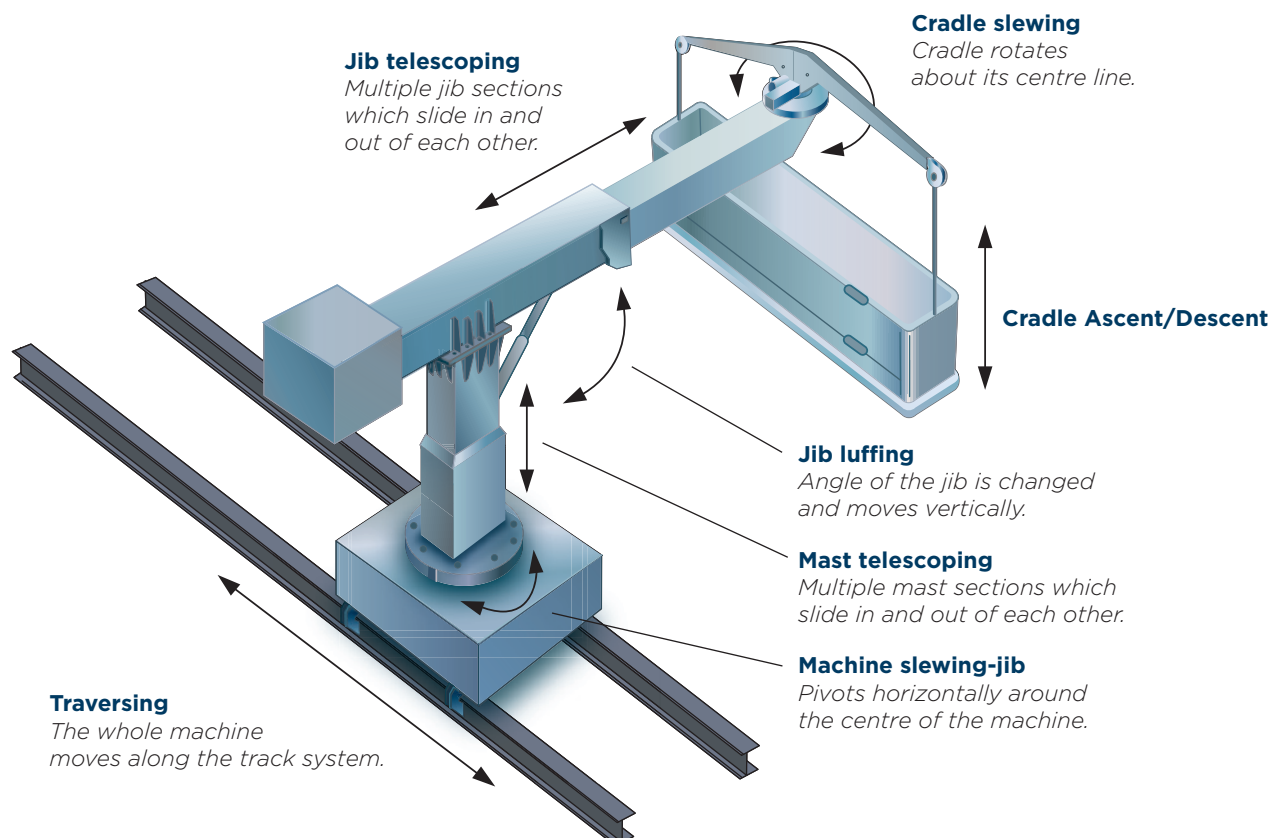



CoxGomyl Machines

Don't Compromise on Safety

Safety is quite literally at the heart of each 5000 Series BMU, with the hoisting system on all machines including multiple standard features to make them as safe and reliable as possible.

Four Wire Ropes

On all machines in the 5000 series range, the cradle is supported by four wire ropes, two attached to each end of the cradle. In the unlikely event of a rope failure, the cradle is still suspended horizontally, providing increased safety to the operators.

Drum Type Hoist

The four wire ropes are wound onto a load-bearing drum, with the cradle being supported by the tension in the ropes. Typically, hoisting ropes on a drum hoist last in excess of 10 years and at least three times as long as those on traction hoists due to less friction and wear, increasing the reliability and reducing the operating costs of the equipment.

'Hardwired' Control Between Roof Car and Cradle

Control signals are carried between the cradle and the control system in the roof car via copper wires wound into each of the hoisting ropes. This provides a continuous 'hardwired' control link between the roof car and the cradle. As the cradle is not subject to interference, which can happen with radio or magnetic communications, a maximum level of safety is provided to the operators.

In addition, there are a host of other safety devices that help ensure that the machine performs safely:

Standard Safety Devices on All 5000 Machines

- Cradle overload device
- Cradle trip bar
- Jib slew end of travel limit switch
- Cradle emergency retrieval hand wind
- Slack rope device
- Over-speed detector and brake
- Emergency stop
- Residual current device
- Cross bar slew end of travel limits
- Electrical phase failure detector
- Harness attachment points
- Cradle full-up detector
- Lanyard restraint trip bar
- Secondary cradle full-up over travel detector
- Wire rope equalizer

Upgrade / Options

- Motor with electric power limiter
- Luffing upper and lower limit switches
- Drum rope over-wind device
- Drum empty limit switch
- Long travel limit

Safety is quite literally at the heart of each 5000 Series BMU.

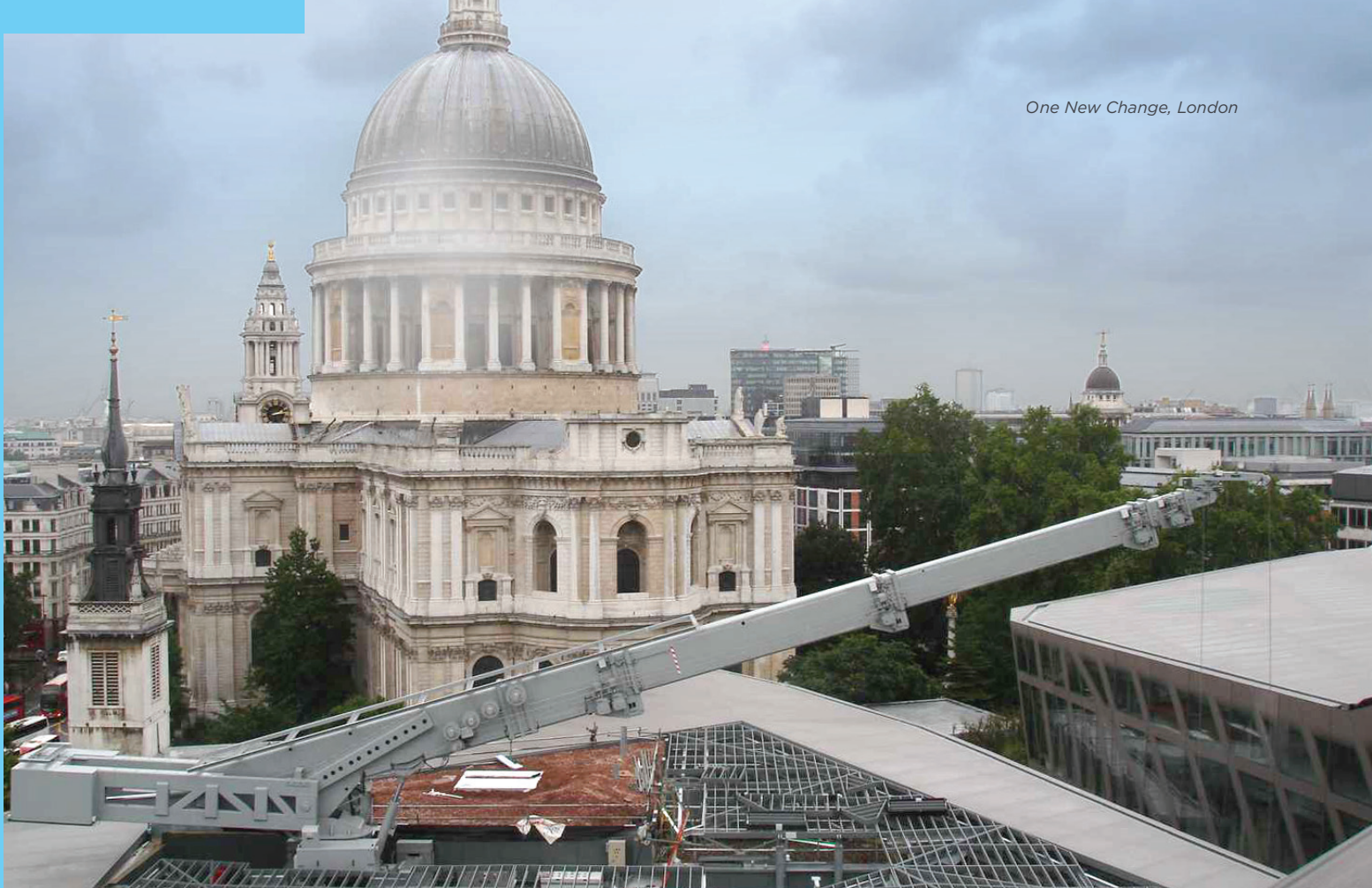

How Can We Help?

Our Services

We take responsibility for producing outstanding building and façade solutions, and as such, are the largest full service provider in the industry. We don't just make machines. We have local experts in engineering, design, project management, implementation, safety and maintenance, to bring a complete "end to end" spectrum of capabilities to your corner of the globe.

From the start of your project we can offer design consultancy, in order to incorporate the latest thinking in building surface maintenance into your building design. Importantly, if done early enough, we can save you money in the long term by designing cost-effective solutions up front, in conjunction with your building design team.

Once the contracts have been let, we can work with you on final drawings and engineering calculations to ensure that all areas of the surface are reached, loads are understood and our project managers are integrating with your teams. From there we go into production and delivery to location, with no site too challenging. CoxGomyl has been involved in thousands of building solutions over the past six decades in over 50 countries around the world.

Our local and regional network of sales offices, project managers, and installation teams will work with you to deliver an installation that is smoothly executed on time and on budget.

After installing, we remain available to assist with the servicing and maintenance during the DLP period, as well as offering ongoing full maintenance and service packages. There is a peace of mind that comes from having your long-life capital equipment maintained fully by the manufacturer. It ensures up time, a clean and well-maintained building, lower cost of ownership, and ultimately assists in the delivery of your value proposition with clients and tenants.



The Latitude, Hong Kong

If you would like to discuss the 5000 Series further, please contact your regional office (see over for details). Remember to consult the 1000 Series and 7000 Series brochures if you feel you require a more standardised or more complex system than outlined within the capabilities of the 5000 series.

With such a vast product range and all buildings being different, we recommend you to consult directly with a CoxGomyl technical advisor, who can assist in developing the optimal solution, the smooth end-to-end planning, and execution of your project. We offer a full-service spectrum from planning to installation and maintenance, to make your job as simple as possible. As a global leader our products can be designed to meet your local industry standards such as EN1808 (European), AS1418.13 (Australian), EN1808 (British, replaces BS6037), ASME A120.1 and OSHA1910.66 (American), GB19154.2003 (Chinese) CAN/CSA.Z271.98 (Canada), SS CP 20/1999 (Singapore) or PB.10.518.02 (Russian). **See our Design, Project Management and Installation publication for further information.**

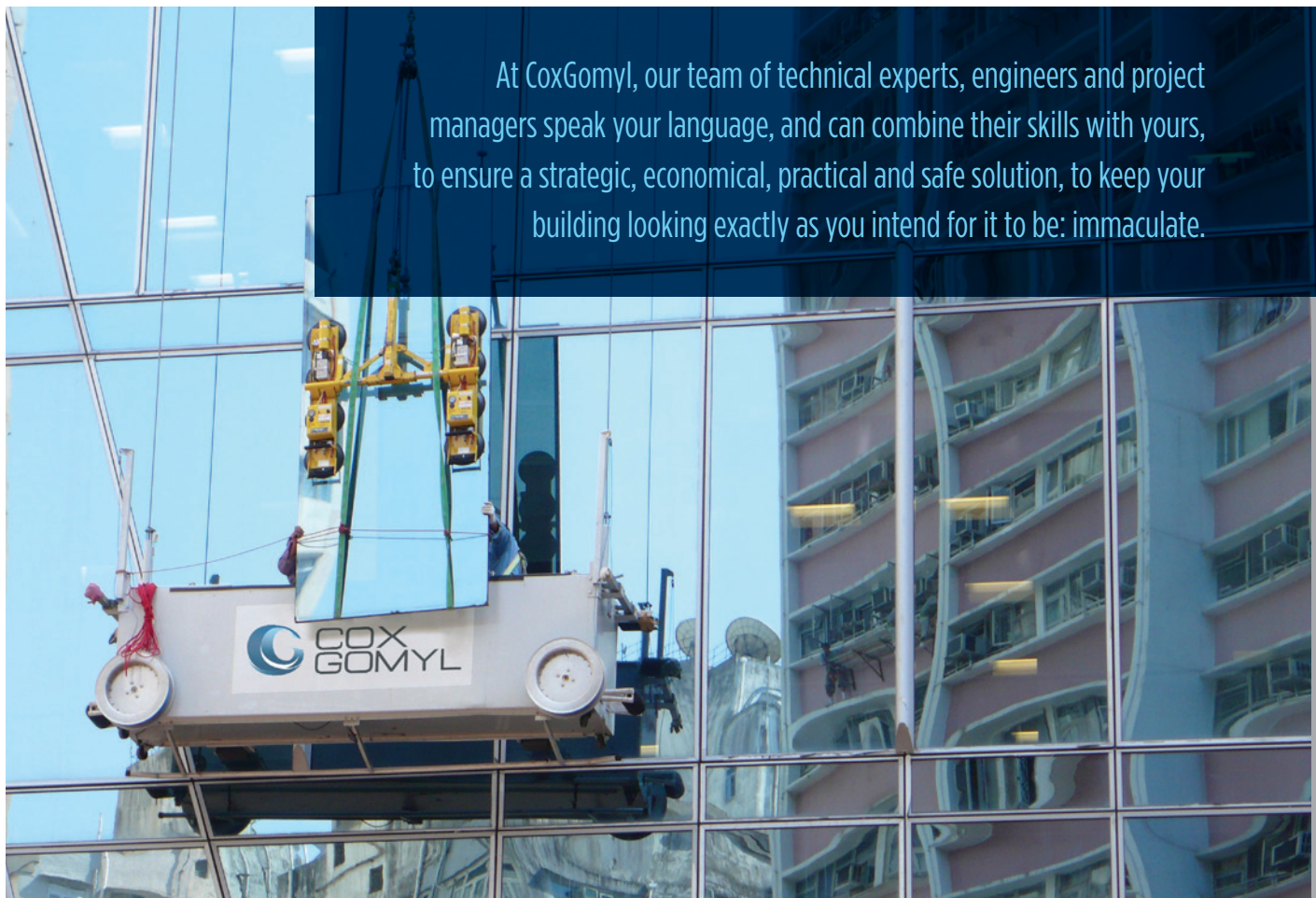

At CoxGomyl, our team of technical experts, engineers and project managers speak your language, and can combine their skills with yours, to ensure a strategic, economical, practical and safe solution, to keep your building looking exactly as you intend for it to be: immaculate.

One Island East, Hong Kong. Example of glass handling

CoxGomyl Office locations:

Head Office

182 Normanby Road
Southbank, Vic 3006, Australia
Phone: +61 3 9673 4444
Fax: +61 3 9673 4400
Email: headoffice@coxgomyl.com

Asia Region

Hong Kong and South China Office
Flat 01, 11th Floor, Eastern Centre
1065 King's Road, Quarry Bay
Hong Kong SAR
Phone: +852 2802 2221
Fax: +852 2824 9626
Email: hongkong@coxgomyl.com

Central and North China Office
Rm 28-011, Hang Seng Bank Tower
No. 1000 Lujiazui Ring Road
Shanghai, China 200120
Phone: +86 21 5465 2455
Fax: +86 21 6467 7507
Email: shanghai@coxgomyl.com

South East Asia Office
29, International Business Park
#05-03A, Acer Building
Singapore 609923
Phone: +65 6513 4780
Fax: +65 6425 6100
Email: singapore@coxgomyl.com

Europe Region

Western Europe and Latin America Office
Ctra de la estacion, naves 3 y 4
28880 Meco (Madrid) Espana (Spain)
Phone: +34 9188 77000
Fax: +34 9188 60514
Email: madrid@coxgomyl.com

United Kingdom Office
19 Schooner Park, Schooner Court,
Crossways Business Park, Dartford,
DA2 6NW, United Kingdom
Phone: +44 1322 221414
Fax: +44 1322 228419
Email: london@coxgomyl.com

Russia and East Europe Office
3Pl. Tverskaya Zastava, Office 240
Moscow, Russia, 125047
Phone: +7 499 250 8975
Fax: +7 499 250 2729
Email: russia@coxgomyl.com

Rest of the World (ROW) Region

Australia and NZ Office
182 Normanby Road
Southbank, Vic 3006, Australia
Phone: +61 3 9673 4444
Fax: +61 3 9673 4400
Email: melbourne@coxgomyl.com

Middle East Regional Office
PO Box 33654
Dubai, UAE
Phone: +971 4 511 8200
Fax: +971 4 511 8300
Email: dubai@coxgomyl.com

Abu Dhabi Branch Office
M/26/22 Musaffah
Industrial Area
Office No. 05
Abu Dhabi Emirate, UAE
Phone: +971 4 511 8200
Fax: +971 4 511 8300

North America Office
216 North Avenue East
Cranford, NJ 07016, USA
Phone: +1 908 325 6587
Fax: +1 908 967 6042
Email: usa@coxgomyl.com

coxgomyl.com

